



THERMIC FLUID HEATER

ABSTRACT

Thermic Fluid Heater is a device which is used in process heating through a heat exchanger, which transfers the heat to the process equipment. The document here describes the details of thermic Fluid heater along with its design and Market Scope.

A

PROJECT REPORT

ON

**“Solid Fuel Fired Vertical Thermal Oil Heater with
stationary combustor”**

UNDERTAKEN AT

“MIT School of Distance Education”

IN PARTIAL FULFILMENT OF

“MBA IN ENERGY MANAGEMENT”

MIT SCHOOL OF DISTANCE EDUCATION, PUNE.

GUIDED BY

“– Dr. Jayant Panigrahi”

SUBMITTED BY

“Dev Ratan Kumar”

STUDENT REGISTRATION NO.: MIT2021C00489

MIT SCHOOL OF DISTANCE EDUCATION PUNE - 411 038

YEAR 2021-23



SUPERTECH ENGINEERS

An ISO 9001-2015 Co.



ENGINEERS, CONSULTANTS, ERECTORS, FABRICATORS, MANUFACTURERS, MECHANICAL, ELECT & INST. CONTRACTORS

605 & 606, 19, KIRTI MAHAL BUILDING, RAJENDRA PLACE, NEW DELHI-110008 (INDIA)

Ph. : 91-11-45041391, 45041393

EMAIL : info@supertechengineers.com; Website : www.supertechengineers.com

CERTIFICATE

This is to certify that..... **Mr.Dev Ratan Kumar...** has completed the project report with us for his project report work on **“Solid Fuel Fired Vertical Thermal Oil Heater with stationary combustor”** in fulfillment for the completion of his Course with MITSDE on **“MBA IN ENERGY MANAGEMENT”** as prescribed By MIT SCHOOL OF DISTANCE EDUCATION, PUNE.

This project is a record of authentic work carried out by him with guidance by our relevant department in a duration of 2021-2023.

Student Sign: -

Student Name:-Dev Ratan Kumar

Student ID: MIT2021C0048



Factories & Offices :

18, 19, Krishna Ind. Area, Village Thatithiya, Bardoly Road, Palsana Taluka, Surat-394305
Plot No. 27, Sector III, IIE Pant Nagar, Rudrapur-263153, SIDCUL, Uttarakhand (India) Ph. : 05944250031

DECLARATION

I hereby declare that this project report entitled “**Solid Fuel Fired Vertical Thermal Oil Heater with stationary combustor**” bonafide record of the project work carried out by me during the academic year **2021-2023**, in fulfilment of the requirements for the award of “**MBA In Energy Management**” of MIT School of Distance Education.

This work has not been undertaken or submitted elsewhere in connection with any other academic course.

Sign:- 

Name:-Dev Ratan Kumar

Student ID: MIT2021C00489

ACKNOWLEDGEMENT

I would like to take this opportunity to express my sincere thanks and gratitude to “– Dr. Jayant Panigrahi” Faculty of MIT School of Distance Education, for allowing me to do my project work in your esteemed organization. It has been a great learning and enjoyable experience.

I would like to express my deep sense of gratitude and profound thanks to all staff members of MIT School of Distance Education for their kind support and cooperation which helped me in gaining lots of knowledge and experience to do my project work successfully.

At last but not least, I am thankful to my Family and Friends for their moral support, endurance and encouragement during the course of the project.

Sign:-



Name:-Dev Ratan Kumar

Student ID: MIT2021C00489

ABSTRACT

Solid Fuel Fired Vertical Thermal Oil Heater With Stationary Combustor is having vertical four pass with Fluidized Bed Combustion (FBC) technology ensuring complete combustion of even low grade coal and husk fuel with virtually nil wastage and achieving high heat operating efficiency. This system is designed with FBC Technology to ensure complete combustion, Help homogeneous mixing of fuel, maintain uniform bed temperature, leaves low unburnt fuel along with the dust collector, I.D. and F.D. fan for balance draft to ensure minimum infiltration of unwanted air through doors & fresh air passes through air pre-heater ensure maximum fuel to heat operating efficiency for any commercial grade of solid fuel. The capacity ranges from 2 Lac to 80 Lacs Kcal/hr. The vertical four-pass thermic fluid heater is suited for Indian industries in rapidly changing and undependable energy situation. The vertical design coupled with integral furnace gives you an assurance of rated output on any solid fuel like Coal, Wood, Husk, Bagasee etc.

TABLE OF CONTENTS

Chapter No.	Title	Page No.
1	Introduction	7
2	Organizational Profile	9
3	Project Objectives and Scope	10
4	To understand the process details of thermic fluid heaters along with its sub-units.	13
5	To understand the Comparison of thermal fluid to steam.	20
6	To Find out some alternate options to increase its heating efficiency.	21
7	To find out the methods to get multiple Energy Outputs for different process usage.	25
8	To find the process of Erection Sequence of Thermic Fluid Heater	26
9	To understand the system with its safety Consideration.	39
10	To understand the installation details along with the safety consideration.	43
11	To understand the codes and Standards being used in Thermic Fluid Heaters.	44
12	Data Analysis	45
13	Conclusion / Findings	49
14	References / Bibliography	50

CHAPTER 1: INTRODUCTION

The high temperature Thermic Fluid Heater is a forced Circulation water tube design in which thermic fluid under pressure circulate through a set of nested coils while draft combustion gases travel across the coils. The hot gases envelop the entire tube surface making maximum use of both Radiant & convective heat to achieve very high heat transfer rates.

A circulating pump is selected to give the proper flow rate and pressure for each application to optimize motor horse power required while maintaining low film temp. to ensure long fluid life. Temperature controls monitor the output temperature and regulates the supply of fuel & air to the furnace to provide efficient combustion of the fuel.

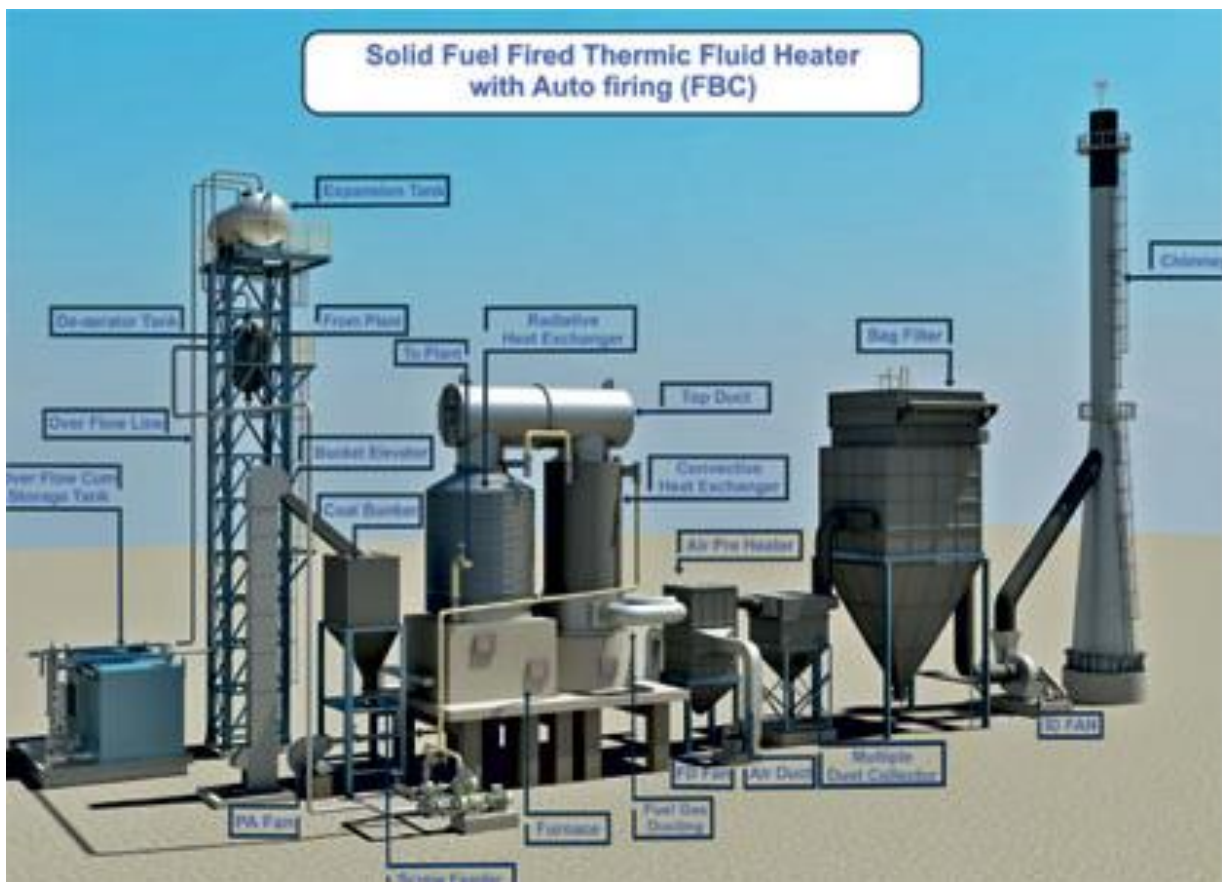

OVERVIEW OF THERMIC FLUID HEATER:-

The New Vertical Four Pass THERMIC FLUID HEATER Is Suitable For Process Industries In Rapidly Changing and Undependable Energy Situations. The Vertical Design Coupled With Integral Furnace Gives You An Assurance For Rated Output On Any Solid Fuel Like Coal, Lignite, Wood, Husk, Bagasse, Etc. THERMIC FLUID HEATER Generic Design Helps In Flexibility Of Fuel Without Any Compromise With Performance.

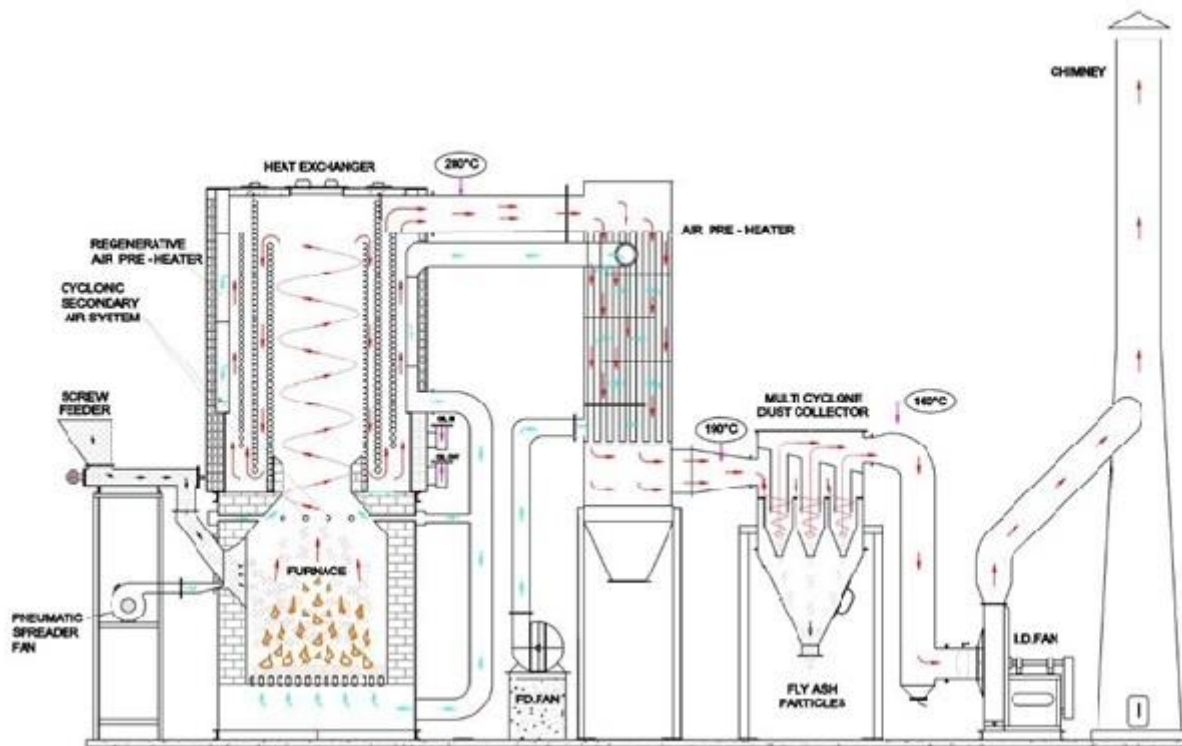

The Four Pass Thermic Fluid Heat Exchanger System comprises of two heat exchangers:-

1)RADIANT HEAT EXCHANGER (FORMS FIRST PASS)

- The coil of radiant heat exchanger is in conical shape and is fabricated out of high heat resistant ERW boiler tube.
- It is mounted on suitable designed furnace.
- It is fabricated out of heavy duty material and provided with necessary fuel feeding arrangement.
- Furnace is constructed with high quality fire bricks and insulation bricks.
- The bricks wall is designed in such a way that it ensures minimum heat loss. The furnace also is equipped with high heat resistant casting .

2)CONVECTIVE HEAT EXCHANGER (FORMS 2nd & 3rd PASS)

Convection zone heat exchanger is designed on coil to coil principle comprising 2 coils fabricated out of high heat resistant ERW boiler tubes. Outer shell of the heat exchanger is covered with high grade insulating materials.

CONNECTING/REFRACTORY DUCT (Between 1st & 2nd PASS)

Both radiant and convective heat exchangers are connected by a specially designed refractory duct which allows flue gas to pass from radiant to convective exchanger.

HISTORY

The modern history of oil began in the 1840s when a Canadian geologist discovered that crude oil could be distilled into kerosene to light lanterns. The invention of heating oil happened soon after when M.A. Fessler invented the oil burner to take advantage of the crude oil discoveries in California.

A **thermic fluid heater** is industrial heating equipment, used where only heat transfers are desired instead of pressure. In this equipment, a thermic fluid is circulated in the entire system for heat transfers to the desired processes. Combustion process heats up the thermic fluid, and this fluid carries and rejects this heat to the desired fluid for concluding the processes. After rejecting it, this fluid comes back again to the thermic fluid heater.

CHAPTER 2: ORGANIZATIONAL PROFILE

Supertech Engineers, Estd. in 1990 is an ISO 9001-2008 Co. certified by TUV-Nord. Since then we have been associated with many well-known industrial houses in India and abroad for execution of EPC projects. We have executed more than 200 projects in India and 15 projects abroad. Our present manpower strength is 650 which include 120 engineers. We have manufacturing units for Process Equipment in SIDCUL at Rudrapur, Utrakhand and Krishna Industrial Area at Surat, Gujarat.

Business Area- Our areas of expertise include Engineering Consultancy, Project Management and allied services in industries as diverse as Petrochemicals, Oil and Gas Refineries, Polymerization, PFY, Film Plants, Pharmaceuticals, Thermal Power Plants, MDF, Sugar, Steel, Super Critical Boilers, IBR and Cross-country Piping including Heavy Fabrications, etc. We are glad to declare ourselves as partner in Corporate Social Responsibility (CSR) schemes like converting Municipal Waste into Energy while taking great care of environment and green surroundings. Recently we have completed one project in Ghazipur, Delhi 12 MW Thermal Power Plant completely working with municipal waste.

Supertech Infracore Pvt. Ltd., Estd. in 1997 for implementation of turnkey projects in the areas of Oil & Gas, Hydrocarbon and Petrochemical industries. We have successfully completed several turnkey projects.

We offer a wide range of services for modifying or expanding existing processes / projects. We have a proven track record in designing and commissioning more than 90 new production facilities and systems in India and abroad. We also manufacture tailor-made critical equipments for specialised industries at our Surat and Rudrapur plants.

We are also approved contractors for Super Critical Boilers from IBR Authority of India across several states.

We have the mindset, resources and experience to undertake challenging projects. Our commitment and involvement in planning and implementation of projects based on different technologies, has earned us an international reputation for efficiency, integrity and successful performance.

Fabrication and Supply

Design, fabrication and supply of plant and equipments, Polyester Chips Dryer System and Accessories, Installation of Plants, Heavy Structural Steel, Alloy Steel and Stainless Steel fabrication as per International Standards.

Piping

Sizes from quarter inch OD to 60 inch OD designed, fabricated and installed to suit exact requirements in materials ranging from Carbon Steel and Stainless Steel to Aluminium and Alloys. Piping and ancillary supports, Cross-country pipelines with 100% Radiography welding.

Site Fabrication

Design and fabrication of pressure vessels as per International Standards in Stainless Steel, Alloy Steel, Carbon Steel or other materials for Chemical Plants and other industries. Fabrication of Storage Tanks and modification of existing Tanks, Vessels/Reactors to suit clients' requirements

E P C Projects

Installation of Vessels/Reactors, Main Plant equipment, Columns and Heat Exchangers for Petrochemical Plants, Refineries, Power Plants and other process industries. Perfect levelling, alignment and fixing as per sequence of erection procedure including hydraulic/pneumatic testing and commissioning.

Accreditations and Recognitions:

Supertech Engineers, Estd. in 1990 is an ISO 9001-2008 Co. certified by TUV-Nord

CHAPTER 3: PROJECT OBJECTIVES AND SCOPE

OBJECTIVE OF STUDY

The objectives of the report on “**Solid Fuel Fired Vertical Thermal Oil Heater with stationary combustor**” are as follows:

1. To understand the process details of thermic fluid heaters along with its sub-units.
2. To understand the Comparison of thermal fluid to steam
3. To Find out some alternate options to increase its heating efficiency.
4. To find out the methods to get multiple Energy Outputs for different process usage.
5. To understand the system with its safety Consideration
6. To understand the installation details along with the safety consideration
7. To understand the codes and Standards being used in Thermic Fluid Heaters

1) To understand the process details of thermic fluid heaters along with its sub-units.

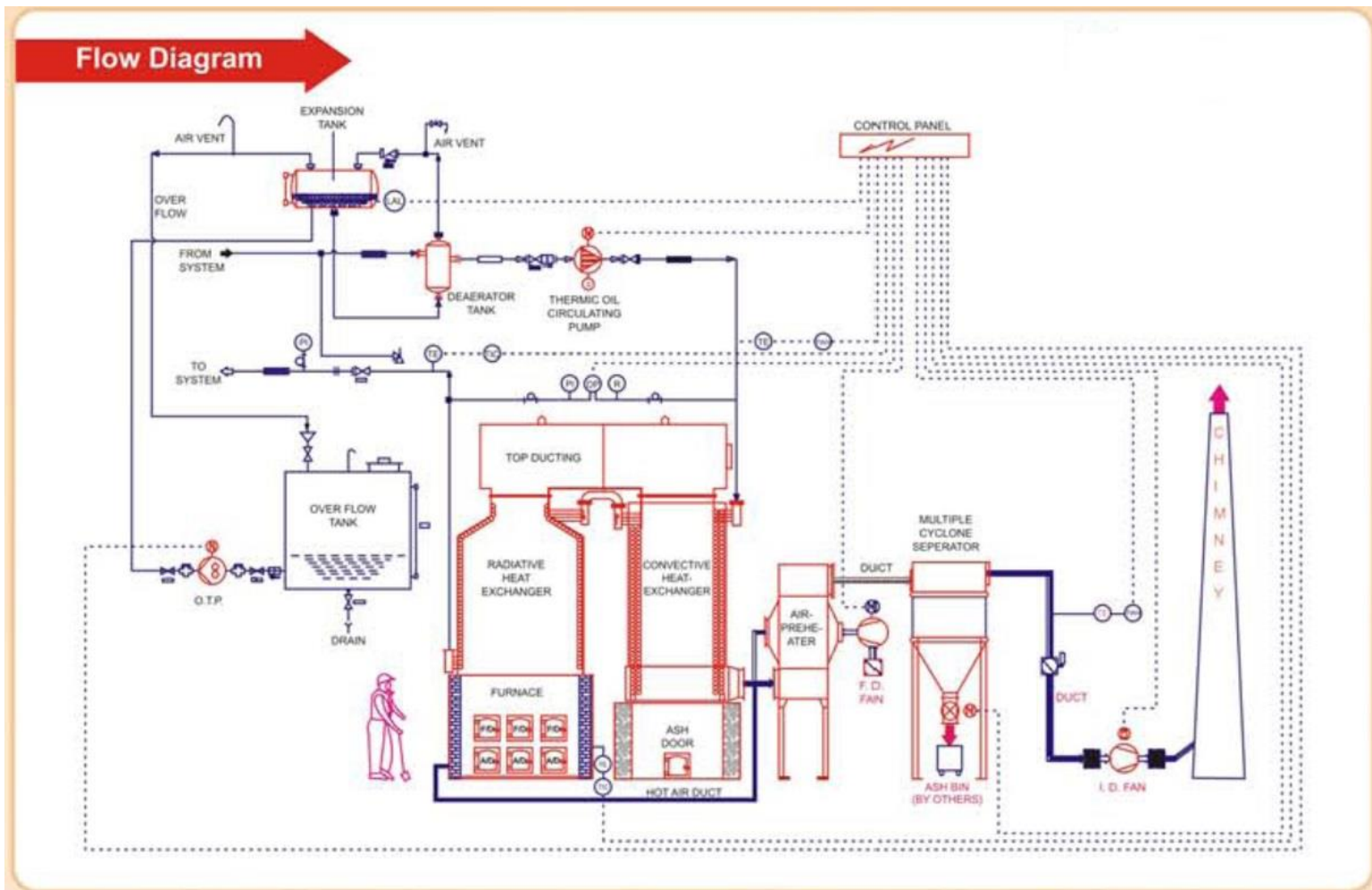

What is a thermal fluid system?

- Thermal fluid (also known as hot oil) systems may be liquid or vapor.
- Vapor phase systems may either incorporate a heater in which vaporization of the fluid takes place within the vessel, or a flooded heater where the fluid is vaporized externally through a flash drum.
- Vapor systems with condensing vapor provide a uniform heat source than liquid phase systems.
- A liquid phase thermal fluid system uses a flooded pressure vessel (heater) in which the heat transfer media (fluid) is heated but no vaporization takes place within the vessel.
- Closed loop systems which may be open or closed to the atmosphere
- Similar in concept to hot water boiler systems

Vapour Phase System:-

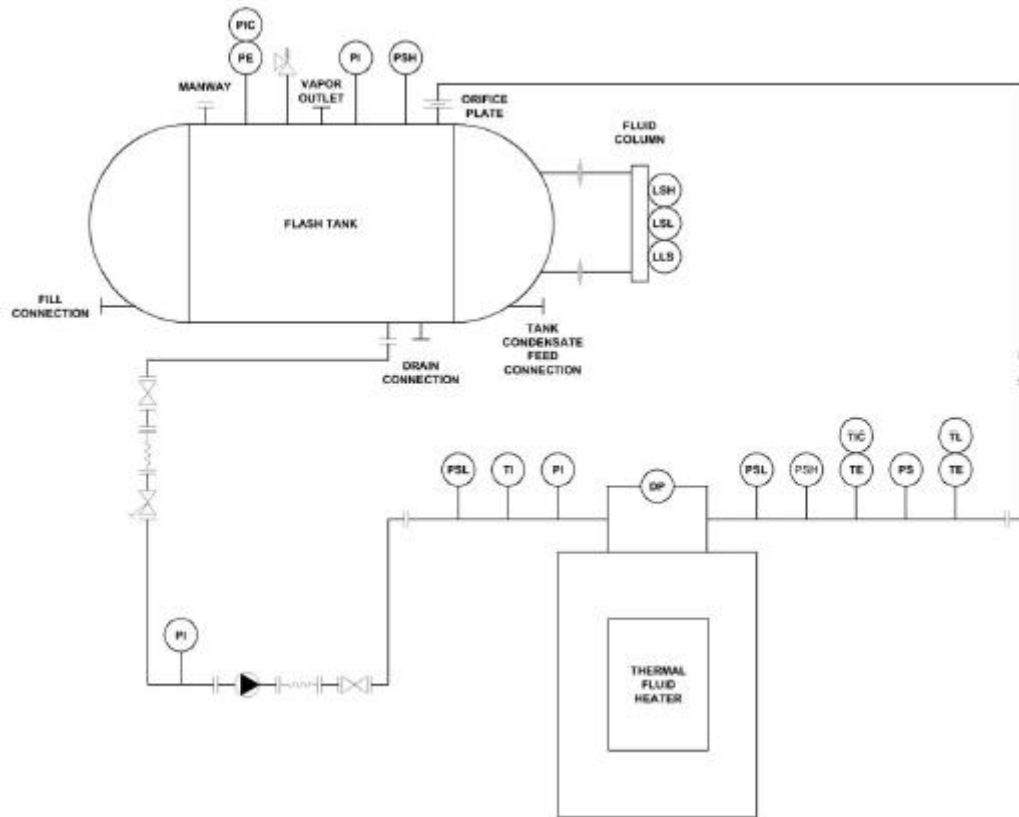

Typical Hot Oil Heat Transfer System Designed to Operate at Atmospheric Pressure

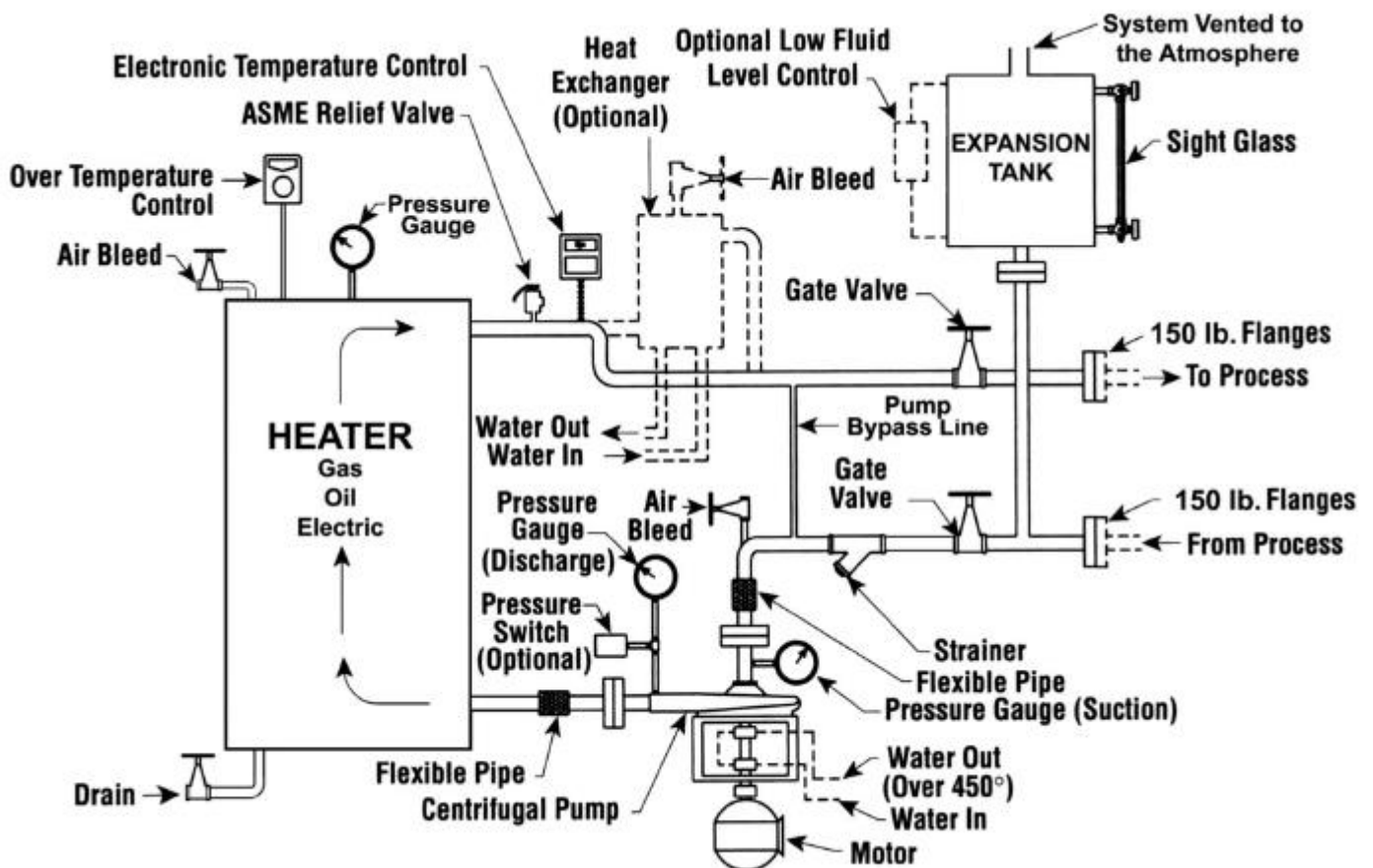

Design Features

- Heaters are commonly direct-fired by combustion of a fuel, or electric resistance elements can be used.
- Heater design may be similar to a fire-tube boiler, electric resistance heated boiler, or a water tube boiler.
- Heaters may operate at temperatures up to 750°F depending on the process requirements and fluid selection.
- Large heaters may be field erected; however, heaters less than 30,000,000 BTU/hr are similar to packaged boilers utilized in a variety of process applications and may be found in typical “boiler room” installations.

Working Principle of Thermic Fluid Heater:-

The basic principle of these heaters is the circulation of thermic fluid through a Closed-loop system. The fluid is heated in a boiler using a fuel source such as gas, oil or coal. The **heated fluid** is then circulated through a heat exchanger, which transfers the heat to the process equipment. The fluid then returns to the boiler for reheating. This closed-loop system ensures that the fluid remains at a constant temperature, making it an efficient and reliable heating system.

There are two main types of **Thermic Fluid Heaters** Coil type and shell and tube type. In the coil type, the **thermic fluid** flows through a serpentine coil, while in the shell and tube type, the fluid flows through a series of tubes surrounded by a shell. Coil-type heaters are more compact and have a faster response time, making them suitable for small-scale applications. On the other hand, shell and tube-type heaters are more efficient and can handle higher temperatures and pressures, making them suitable for large-scale industrial applications.

Now, let us look at the various applications of **Thermic Fluid Heaters**. These heaters are widely used in industries that require precise and continuous heating. In the chemical industry, they are used for heating reactors, distillation columns, and other process equipment. In the pharmaceutical industry, they are used for heating ovens, dryers, and other equipment that require a controlled temperature. In the food and beverage industry, **Thermic Fluid Heaters** are used for heating cooking vessels, pasteurizers, and other processing equipment. They are also used in the paper and textile industry for drying and curing processes.

One of the main advantages of **Thermic Fluid Heaters** is their high efficiency. As the fluid remains at a constant temperature, there is no loss of heat during the transfer process, resulting in lower energy consumption and cost savings. Another advantage is their versatility, as they can be used for a wide range of temperatures (-20°C to 350°C) and pressures (up to 10 bar). They also have a quick response time, making them suitable for processes that require a rapid heating or cooling rate. Moreover, these heaters are easy to operate and maintain, making them a preferred choice for many industries.

In addition to their advantages, there are some challenges associated with **thermic fluid heaters**. The most significant challenge is the risk of fluid leakage, which can be hazardous to the environment and the workers. To mitigate this risk, regular maintenance and inspection of the system are necessary. Another challenge is the initial cost of installation, which can be higher compared to other heating systems. However, the long-term cost savings and efficiency make it a worthwhile investment.

In conclusion, **Thermic Fluid Heaters** are an essential component of many industrial processes. They provide efficient and precise heating, making them an ideal choice for various industries. With advancements in technology, these heaters continue to improve in terms of efficiency, safety, and cost-effectiveness. As industries strive for more efficient and sustainable practices, **Thermic Fluid Heaters** will continue to play a crucial role in meeting their heating requirements.

The complete design is of the heater is designed as per India standards mentioned in IS 13306 : 1992 (INDIAN STANDARD OIL AND GAS FIRED THERMIC FLUID HEATERS – METHOD OF CALCULATION OF FILM TEMPERATURE)

Major Equipment

- Fuel Feeding System
- Thermic Fluid Heater
- Air Pre-Heater
- Cyclone Separator
- Bag Filter
- Chimney
- ID Fan
- FD Fan
- De- Aerator Cum Expansion Tank
- Fluid Pump
- Diesel Engine

Fuel Feeding System:-

Conveyor is mostly used to handle the feeding System. Multiple fuels like wooden chips, Rice husk, Soya etc are being used in the furnace of Thermic Fluid Heater.



Thermic Fluid Heaters:-

The fuel is fed through the conveying system to the Furnace chamber and the heat produced is transferred to the Thermic Fluid Oil running in the tube.

APH:-

Flue Gas duct is passed through the APH and the heat is utilized to preheat the Plenum Chamber Air.

Cyclone Separator:-

As the flue gas contains heavy ash/dust particles, so it is passed through the Cyclone separator and this causes the collection of heavy ashes up to 10 micro meter size at the bottom section of the Cyclone.

Bag Filter:-

In order to use the fine filtration bag filters are used and they provide filtration for small solid particles of particle size in the 1–1200 μm range, with flow rates between 1 and 1000 m^3/h and for low solid concentrations.

Chimney:-

For Safe Exhaust of the Flue, Gas chimney is being used.

ID fan:-

To maintain the draft inside the furnace ID fan is used.

FD Fan:-

FD fan is used for the bed fluidisation of the furnace chamber.

De-Aerator Cum Expansion Tank:-

For Every 100 deg C the volume expanded by 7%. This expansion volume is being controlled by Expansion tank.

Thermic Fluid Pump:-

Thermic fluid oil transfer is being done by this centrifugal pump.



2) To understand the Comparison of thermal fluid to steam:-

Why use thermal fluid instead of steam?

- No corrosion or freezing concerns
- Simple circuit; no blow downs, steam traps, or condensate return systems
- Minimal maintenance
 - No hand-hole gasket replacement
 - No re-tubing
- No water treatment requirements
- High operating temperatures obtained with minimal system pressures (system pressure drop only).
- If a process requires heating and cooling, it may be done with a single fluid.

Steam Pressure Comparison Steam vs. Thermal Fluid

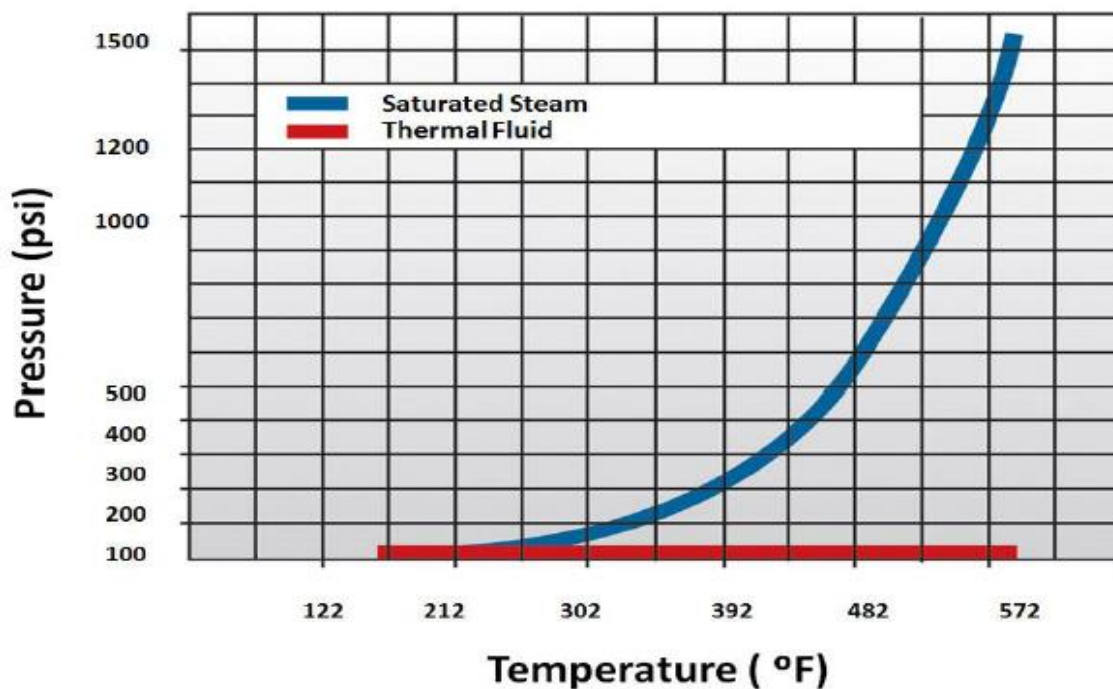

3) To Find out some alternate options to increase its heating efficiency.

In this section we will discuss about the option where we can enhance the energy Usage.

A) The furnace Mechanical frame can be used as a tube panel, which can be the oil jacket or steam jacket.



B)Another alternate option is to provide superheating coils in between the furnace bed.



C)The third option is to place coil type module in the flue Gas Duct.



D)The Plenum Chamber of the fluidizing bed should be insulated to avoid the heat loss. The Insulation application will help to use effective heat getting extracted from APH.

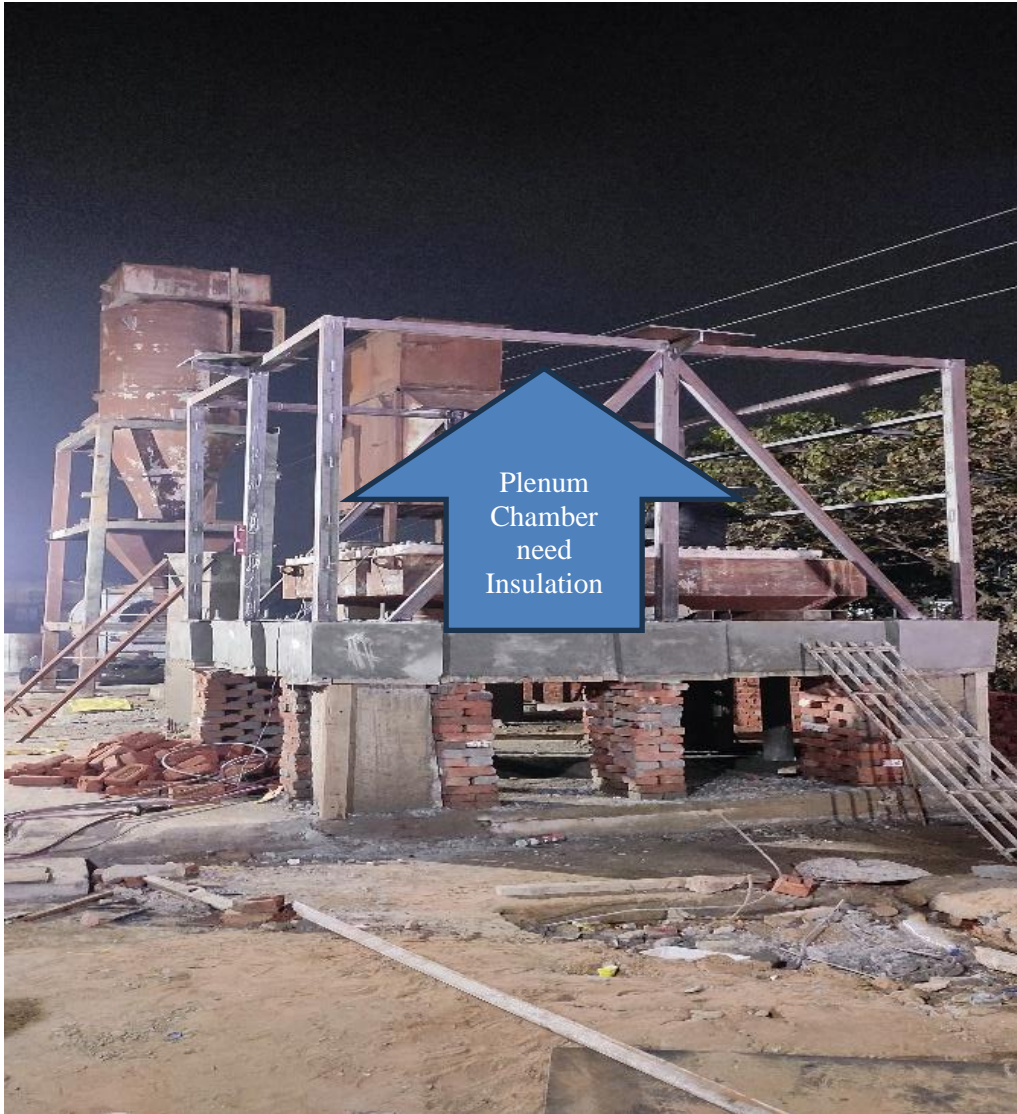

4) To find out the methods to get multiple Energy Outputs for different process usage.

Hot Oil can be utilized with the following types of Usage:-

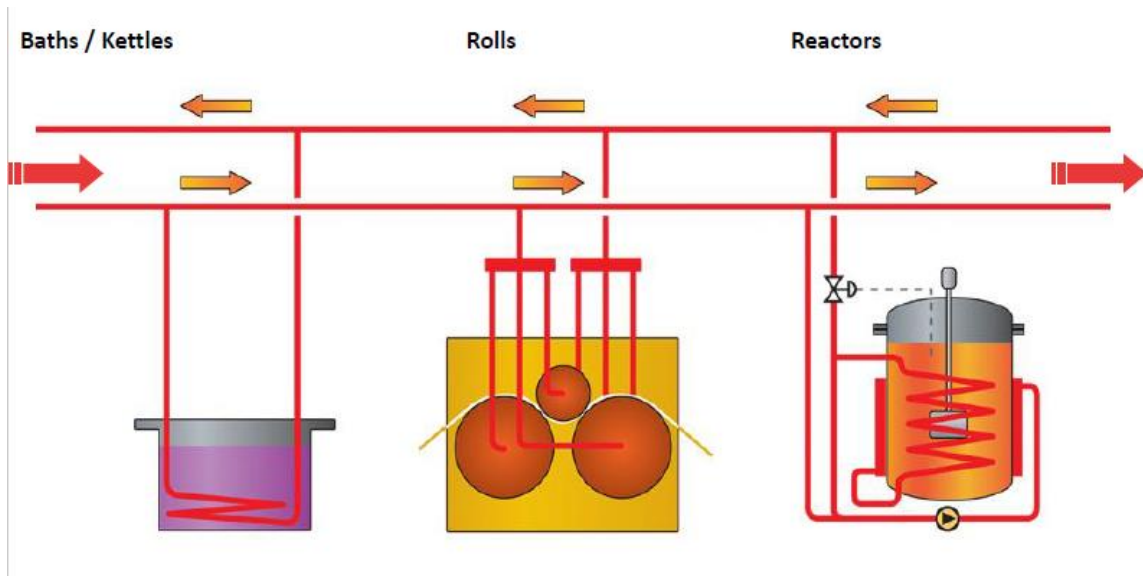
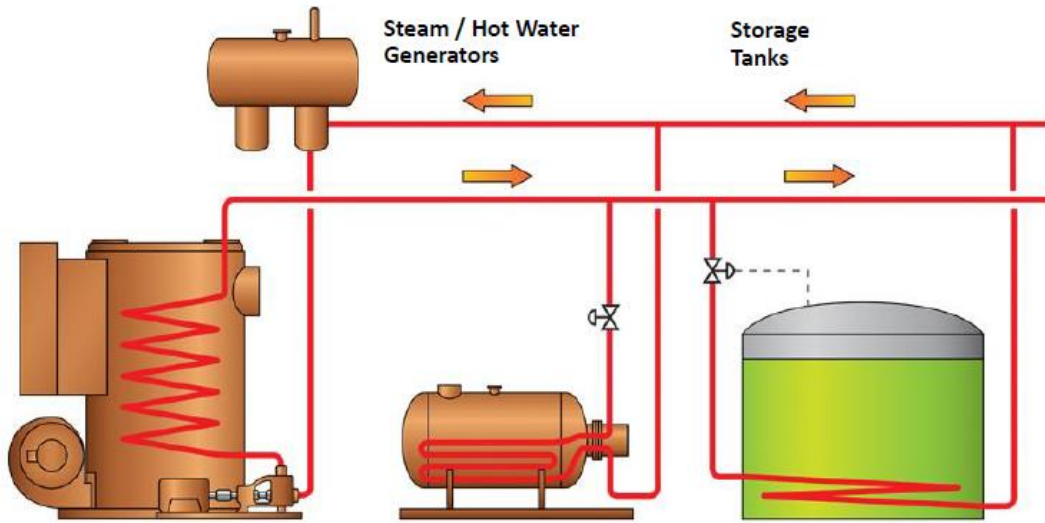

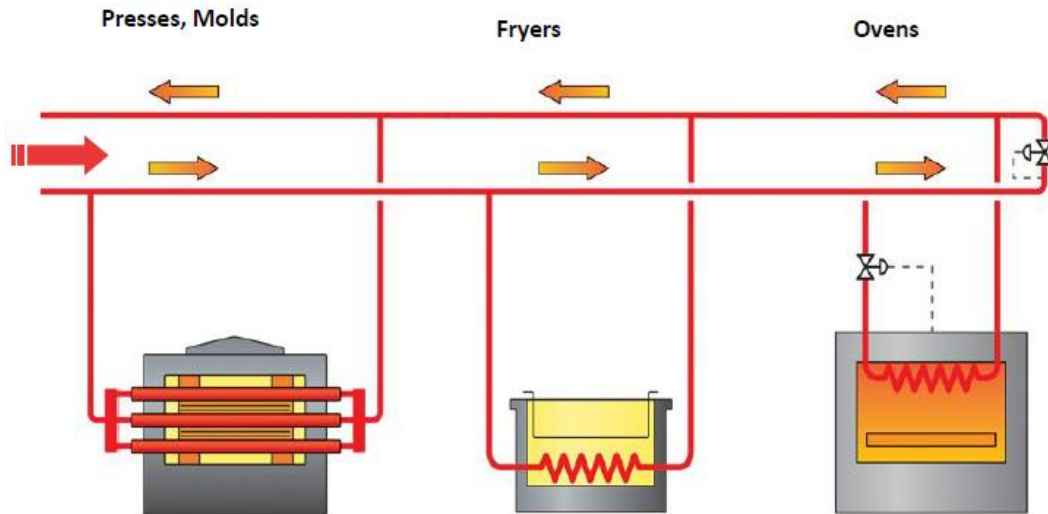

5) To Find out the process of Erection Sequence of Thermic Fluid Heater Project.

This Section Includes the Execution Sequence of Civil, Mechanical & Electrical Work related to completion of Thermic Fluid Heater Project. Let us begin with the Civil Execution plan.

The civil execution starts with identifying the actual north of the plant, which is 18 degrees deviated from the geographical North.

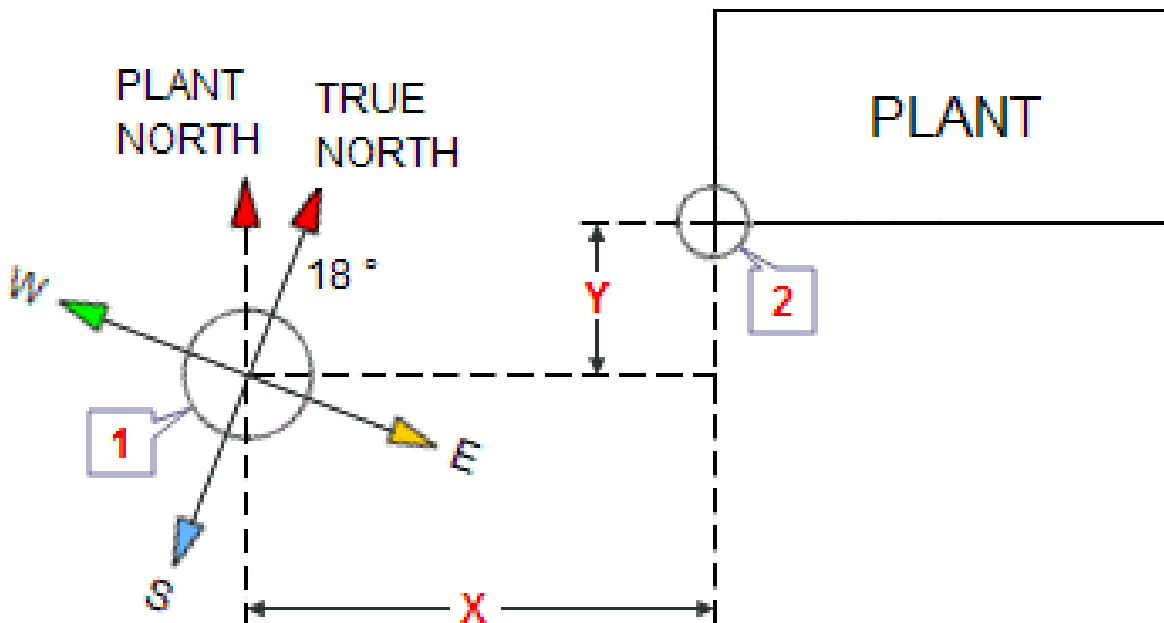

Based on the above mentioned the point of start of civil work is identified (Reference Point is mark and then based on the plot plant Excavation, PCC , RCC and Handing Over to Mechanical team is done) and the below steps is followed to start the civil work:-

Plot Plan Study:-

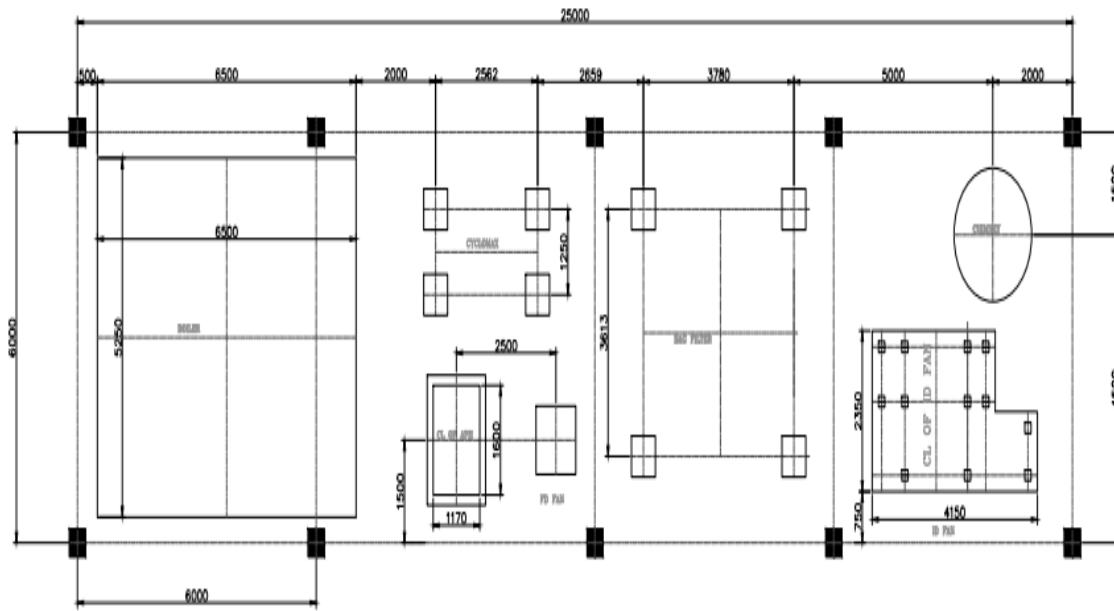

Excavation:-



PCC:-



RCC:-

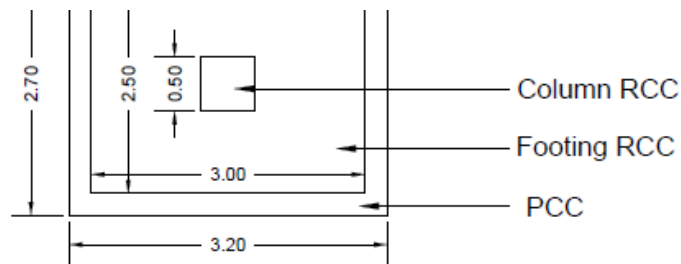

Footing Details

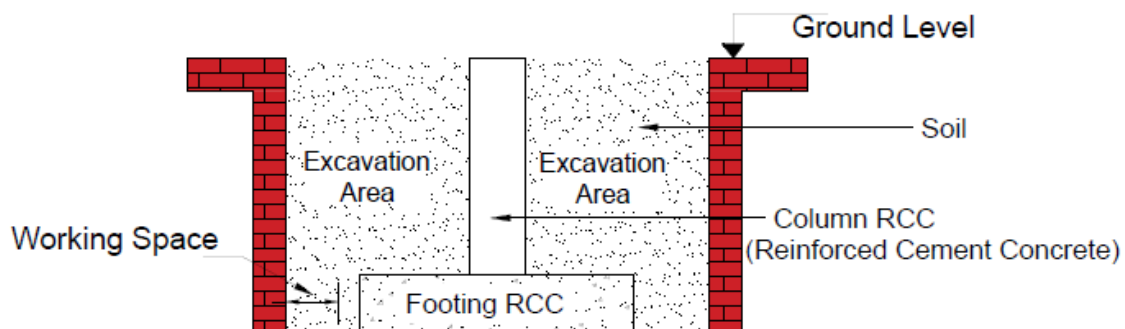

Steps of mechanical Execution is as follows:-

1) Civil Foundation Excavation, PCC & RCC Work Completion.(The original civil Execution of the Solid Fuel Fired Thermic Fluid Heater is mentioned in the below image.)The civil structure for the mechanical Equipment is prepared and the same is handed over to Mechanical team for further Execution.



2) Placement, Erection & Alignment of the Fluidised Bed



3) Fabrication ,Erection & Alignment of Mechanical Frame



4) In Parallel, Preparation Of civil column for convective coil



5) Placement, Erection & Alignment of the Radiant Coil



6) Placement, Erection & Alignment of the Convective Coil



7) Placement, Erection & Alignment of the Flue Gas Duct



8) In Parallel the work done is Placement, Erection & Alignment of APH Frame & APH.



9) Placement, Erection & Alignment of Cyclone Frame & Cyclone.



10) Inter Connecting Duct erection, alignment and Weld Completion

11) ID fan Erection and Alignment



12) FD fan erection and alignment



13) Thermic Fluid pump erection and Alignment



14) Bag Filter Erection and Alignment



15) De-Aerator Cum Expansion Tank erection and Alignment

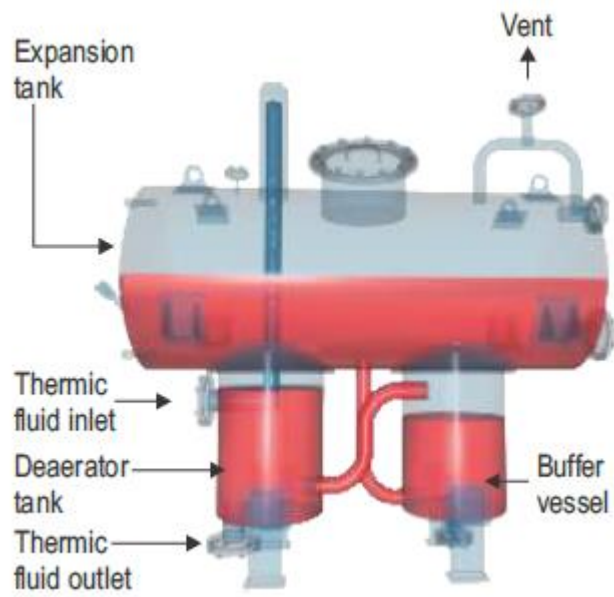

16) Inter Connecting Pipe and Fittings Installation

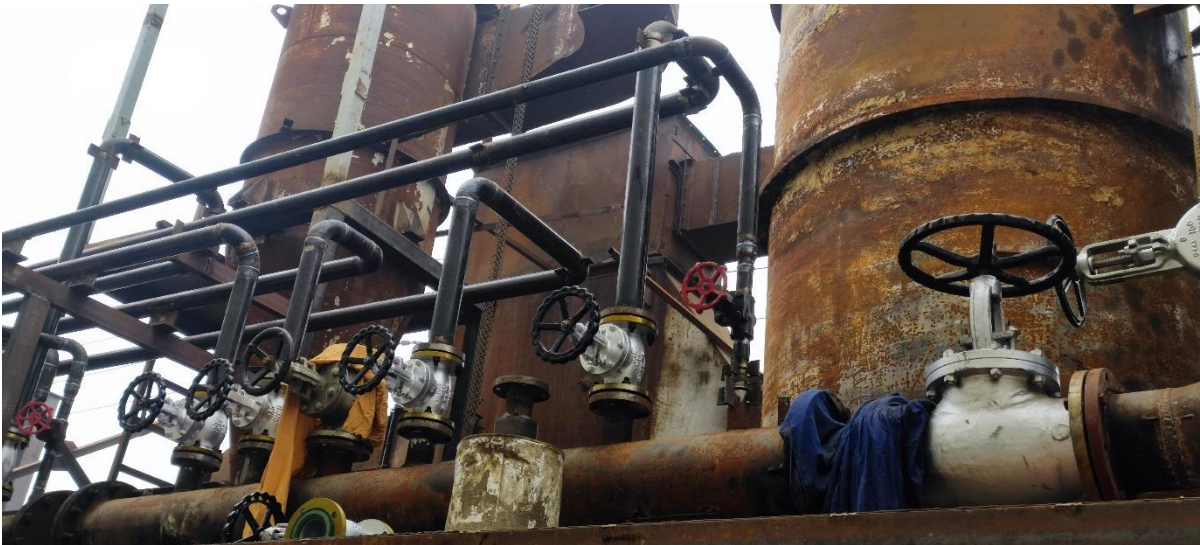

17) Storage tank Erection and alignment



18) Chimney Erection & Alignment



6) To understand the system with its safety Consideration

System and Safety Considerations

- Thermal fluid selection
- Pump and proof of flow
- Fluid excess temperature protection
- Stack excess temperature limit
- Expansion tank design and fluid level

Thermal Fluid Selection

- Vapor pressure/boiling point
- Special construction requirements if the operating temperature exceeds the boiling point
- .
- Some common thermal fluids include:
- Dow Dowtherm A, G, RP
- Monsanto Therminol 55, 59, 66
- Paratherm NF, HE
- Petro Canada Calfo AF, Purity FG

Thermal Fluid Maintenance

- Fluids should be tested annually.
- Lubricating oil tests that include dissolved metals are not adequate.
- Do not top off with different thermal fluid chemistry.
- Mineral oil/petroleum vs. synthetic/aromatic.
- Track heater inlet and outlet temperatures and pressures.
- Always record the date and the amount of fluid addition.
- Changing the type of fluid used in a system may require a change in the system components (pump, expansion tank etc.).
- Chemical cleaners may also be required.

Thermal Fluid Pump

- Must be designed for use with thermal fluids at temperature
- Standard hot water and boiler feed pumps are not appropriate.
- Pumps may be air cooled, water cooled, canned or mag drive designs.
- The pumps are sized to overcome the pressure drop in the system and must be sized based on the specific gravity of the fluid at operating temperature.

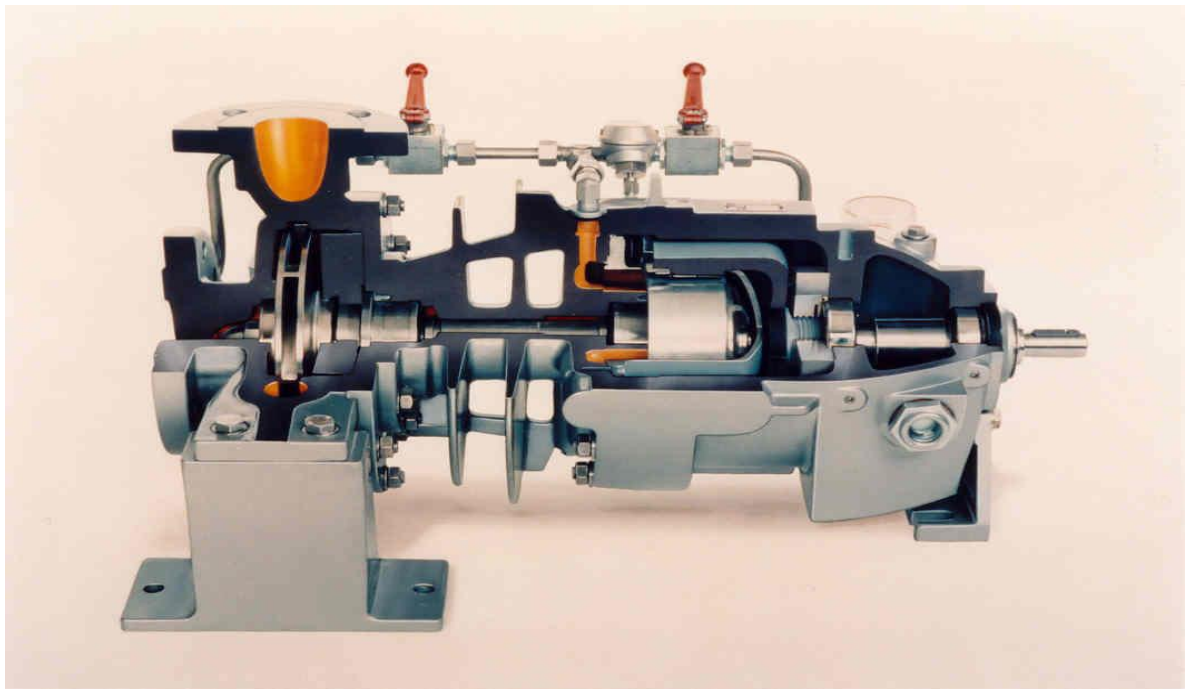

Proof of Fluid Flow

- Proof of fluid flow is critical for vessel longevity and system integrity.
- Means should be provided to prove minimum fluid flow through the heater at all operating conditions to ensure proper velocities and film temperatures.
- A low flow condition can cause overheating, degradation of the fluid, or heater coil/tube failure.
- Proof of flow is typically interlocked into the combustion circuitry
- Means to prove flow may include vortex shedding meters, flow switches, pressure switches, an orifice or a differential pressure switch.

Fluid Excess Temperature Protection

- This limit prevents the fluid temperature from exceeding the maximum allowable temperature of the specific fluid. It should be set no higher than the maximum bulk temperature of the fluid.
- The temperature sensing device should be compatible with the fluid and the system operating temperature and pressure and located at the heater outlet.
- It is generally interlocked into the combustion safety circuitry and often incorporates a manual reset functionality.

Stack Excess Temperature Limit

- Many installations include a high stack temperature switch interlock.
- In the event of a high stack temperature this device shuts off the burner and circulating pump.
- The manufacturer of the heater determines the acceptable stack temperature for the heater.
- A high stack temperature indicates improper combustion (or soot build up) or a failed coil.
- Manual reset is recommended.
- The stack limit may be part of an inert gas smothering system.

Expansion Tank Design

- Fluid selection, system volume and operating temperature will impact expansion tank size.
- Depending on the fluid selection and operating parameters, systems may be open or closed to the atmosphere.
- Closed systems may be pressurized with an inert gas blanket.
- An ASME tank may be required.

When should a pressurized expansion tank be used?

- The tank is not the highest point in the piping system.
- The tank contents can be at a temperature such that exposure of the fluid to the air would cause degradation of the fluid.
- The fluid is operated above its atmospheric boiling point.
- The fluid manufacturer recommends the use of an inert blanket.

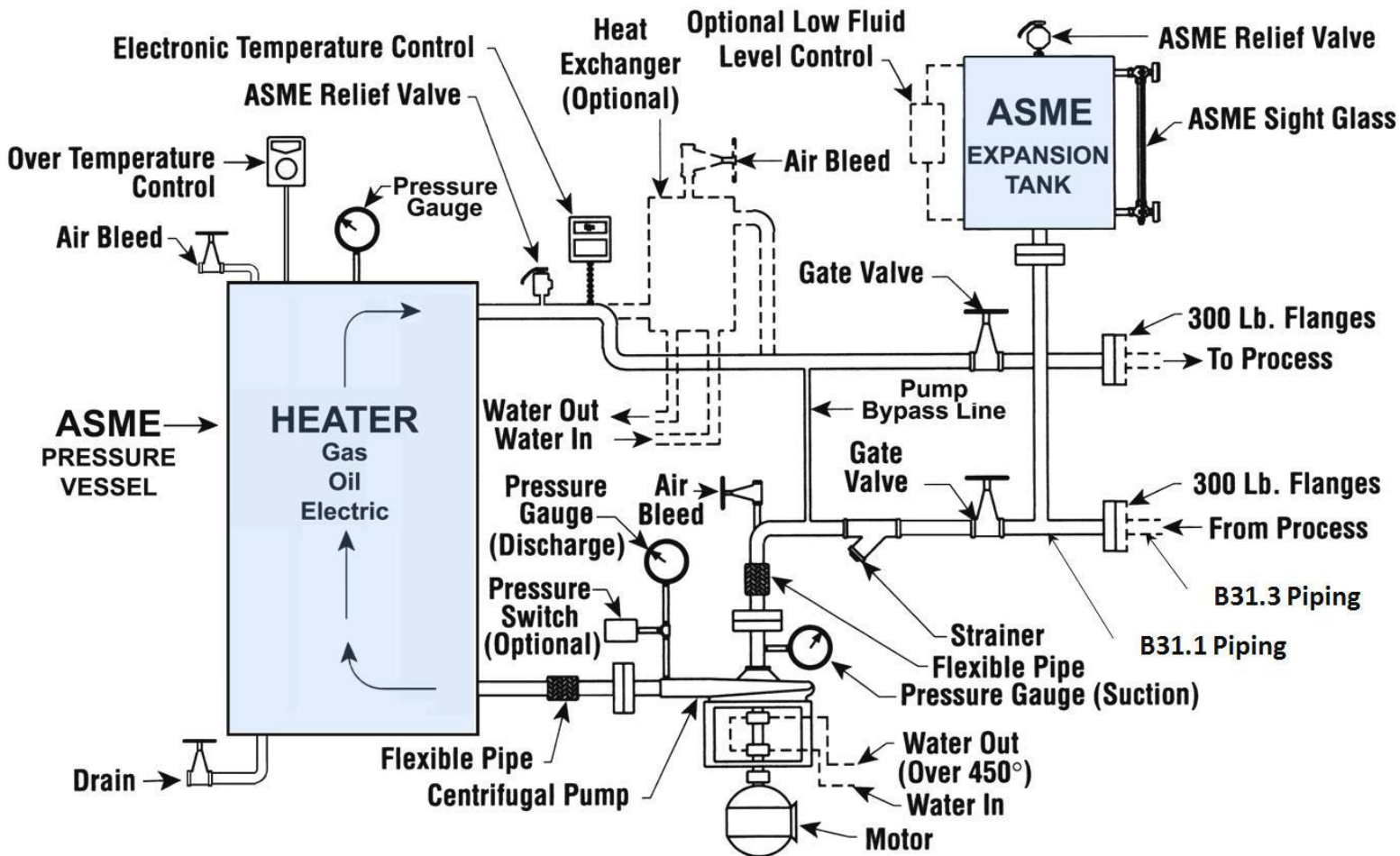

TYPICAL ASME HOT OIL HEAT TRANSFER PRESSURIZED SYSTEM (OVER 15 PSIG)

Expansion Tank – Fluid Level

- A minimum liquid level must be maintained in the expansion tank to prevent pump cavitation.
- A liquid level switch or similar device is typically provided and interlocked with the pump and burner to shut them down in the event of a low fluid level condition.
- The switch should be satisfied before the pump can start.

Installation

- Combustion air and ventilation requirements are similar to those of power or heating boilers and determined by the manufacturer.
- A containment curb or seal welded drip lip on the heater skid should be considered.
- Piping, valves and system components are rated for the temperature and pressure of the system
 - Brass, bronze, Aluminum and cast iron components are not recommended.
 - Any sign of leaking piping is a safety concern, as the fluid or its Vapors can be hazardous or flammable.
 - Piping should be welded or flanged where possible and **pneumatically** tested for leaks.

Installation

- Pressure relief devices
 - The pressure relief valves should be a totally enclosed type with no lifting lever.
 - The discharge piping of the pressure relief valve should be connected to a closed vented storage tank.
- Insulation
 - The insulation should be selected for the intended purpose.
 - Where there is a potential for fluid leaks, the insulation should be non-absorbent.

ASME Section I Requirements

- Organic Fluid (thermal fluid) Vaporizers
 - Rules in Part PVG are applicable and are used in conjunction with the general requirements of Part PG.
 - Part PVG addresses the pressure relief valves, gage glasses and drain valves.
- Liquid phase thermal fluid heaters
 - Applicable requirements for liquid phase heaters are not clearly identified.
 - There is an open item in progress to define the Section I rules for these heaters.

Controls and Safety Devices for Automatically Fired Boilers (CSD-1)

- CSD-1 applies to Power Boilers and Heating Boilers with inputs less than 12,500,000 BTU/hr. It includes requirements for combustion controls as well as steam and waterside control (including pressure, temperature and water level).
- With the current Standard, questions exist regarding the applicability of CSD-1 to thermal fluid systems.
 - Combustion controls covered in CSD-1 are applicable to thermal fluid heaters.
 - However, Part CW, Steam and Waterside Control, does not cover the requirements for thermal fluid systems.
- A task group was formed in CSD-1 to review and define the specific requirements for thermal fluid systems.

National Fire Protection Association, NFPA-87

- While NFPA 85 (boilers) and NFPA 86 (ovens) provide excellent information regarding combustion controls, neither Standard was directly applicable to thermal fluid heaters.
- Recommended Practice for Fluid Heaters, NFPA 87, was developed.
 - Topics covered include:
 - Location and Construction
 - Heating Systems
 - Commissioning, Operations, Maintenance, Inspection and Testing
 - Heating System Safety Equipment and Application (combustion & temperature control)
 - Chapters specific to thermal fluid heaters (pumps, expansion tanks etc.)
 - Fire Protection

CHAPTER 4: DATA ANALYSIS AND INTERPRETATION

Thermic Fluids Market Size (2021–2028)

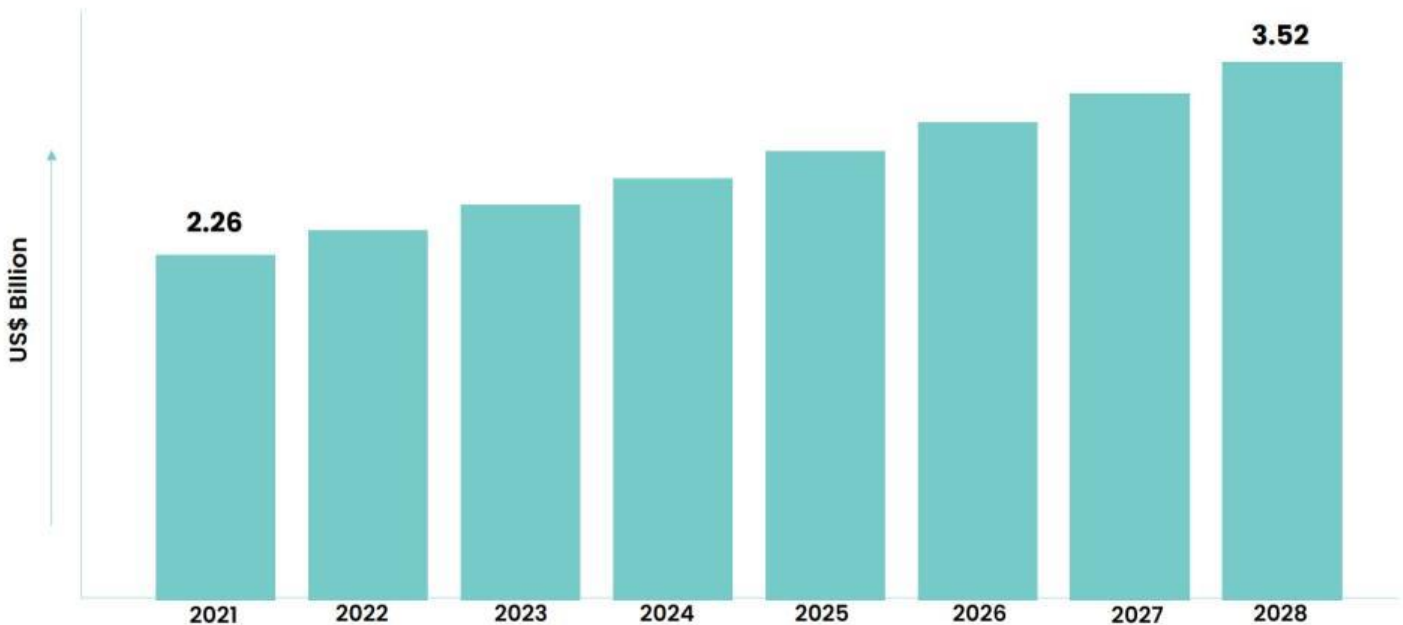

Report Overview

The **Heat Transfer Fluids Market** Was Valued At **USD 4.9 Bn In 2022** and Is Expected To Reach **USD 8.3 Bn In 2032**, with A **CAGR of 5.6%** From 2023 To 2032.

In 2022, the Global Heat Transfer Fluids Market accounted for USD 4.9 billion. Between 2023 and 2032, this market is estimated to register a CAGR of 5.6%. The market for heat transfer fluids creates and distributes fluids for use in heat transfer.

A number of industries may utilize heat transfer fluids to move heat from one place to another. Heat transfer fluids are used in industrial operations like chemical processing and power generation, oil and gas extraction as well as heating, air conditioning systems, and ventilation.

The requirement for advanced thermal management systems, rising industrialization, and rising demand for energy-efficient solutions are some of the factors driving the anticipated growth of the global market for heat transfer fluids in the upcoming years.

Global Heat Transfer Fluids Market

Size, by type, 2022-2032 (USD Billion)

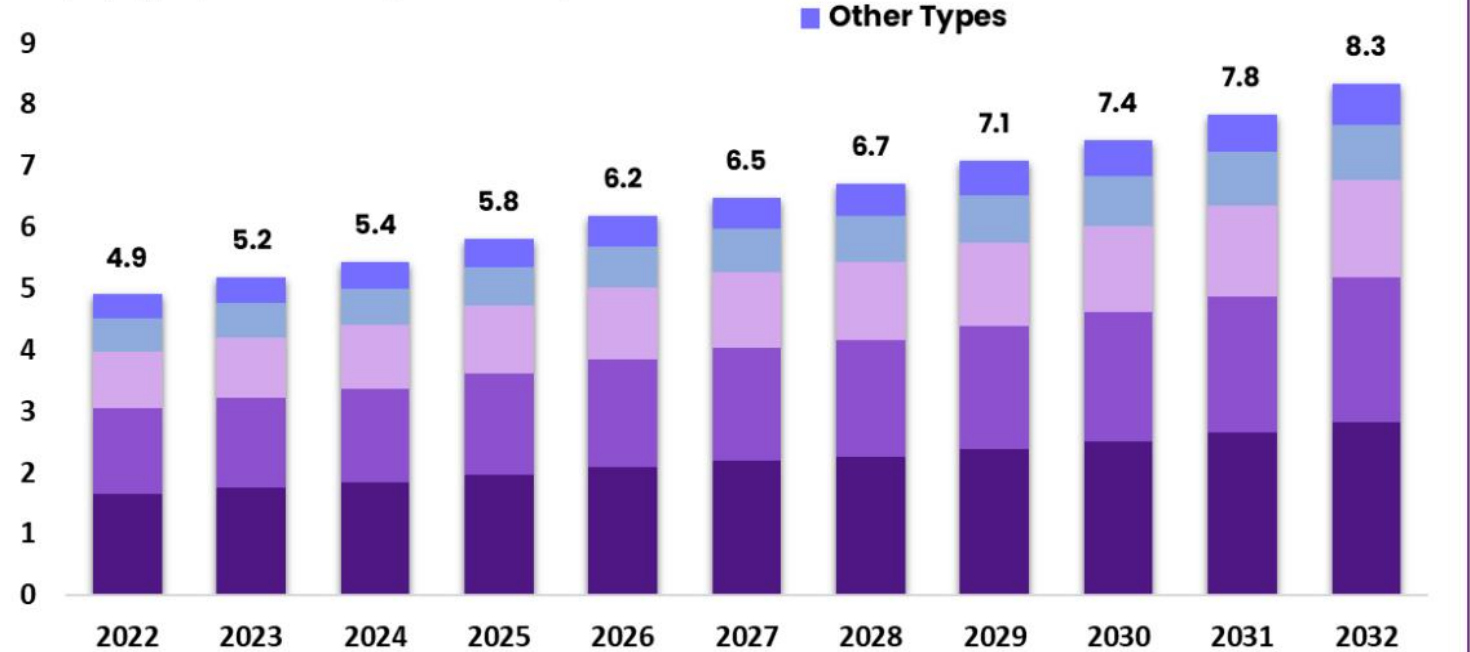

The Market will Grow At the CAGR of:

5.6% The forecasted market size for 2032 in USD:

\$8.3B

market.us
ONE STOP SHOP FOR THE REPORTS

Regional Analysis

North America Accounted for the Largest Revenue Share in Heat Transfer Fluids Market in 2022.

North America is estimated to be the most lucrative market in the global heat transfer fluids market, with the largest market share of 46.2%, and is expected to register a CAGR of 4.9% during the forecast period.

The North American region is predicted to have the greatest share of the global market for heat transfer fluids due to the expansion of many industries, including chemical, oil and gas, automotive, and other sectors. The region's established infrastructure and high level of technological development are predicted to be the main factors driving the demand for improved heat transfer fluids.

Asia-Pacific is Expected as Fastest Growing Region in Projected Period in Heat Transfer Fluids Market.

Asia-Pacific is expected as the fastest-growing region in the forecast period in the heat transfer fluids market with a CAGR of 5.3%. The market for heat transfer fluids is anticipated to

expand at the fastest rate in the Asia-Pacific region, driven by the expansion of a number of sectors including the chemical, oil and gas, and automotive industries.

Global Heat Transfer Fluids Market

Regional Analysis in 2022

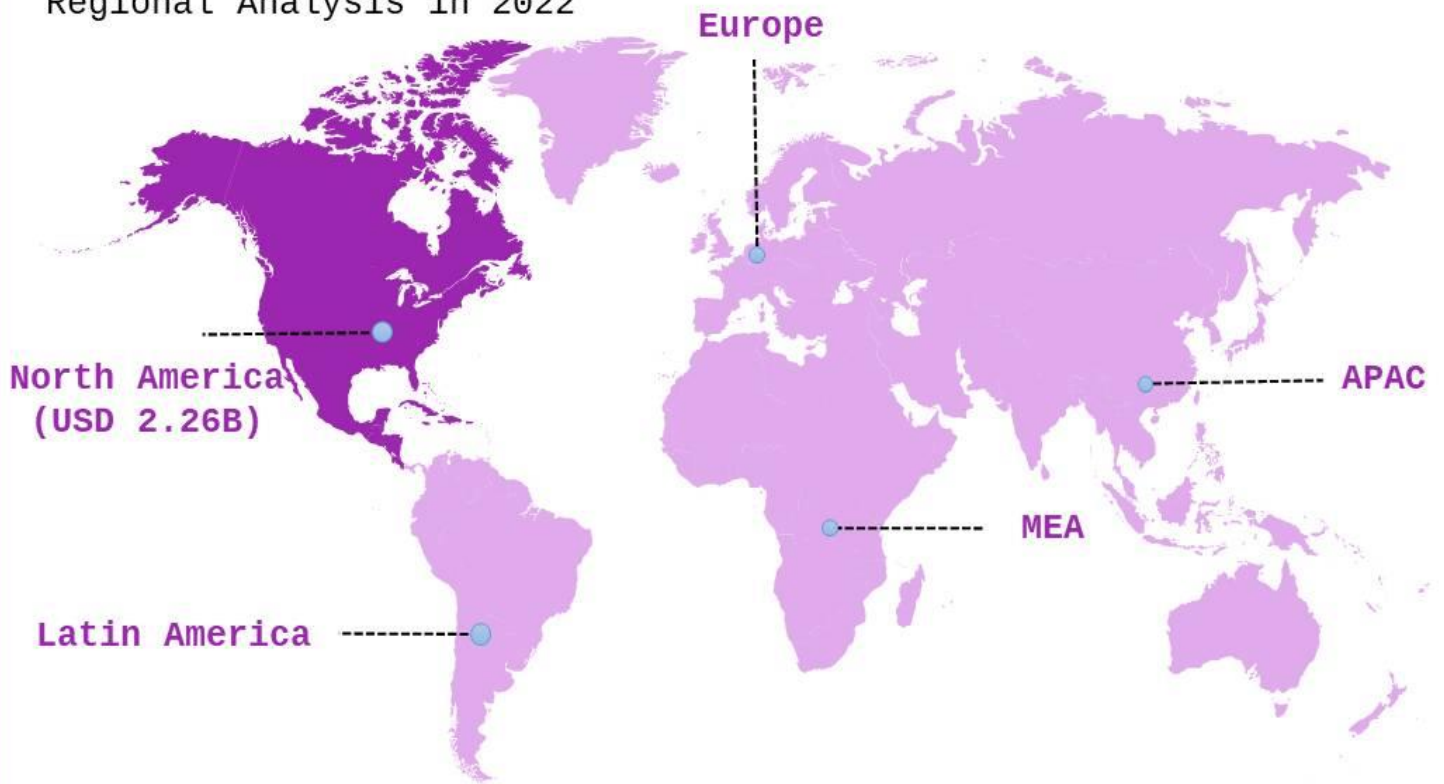

North America is Expected to hold The largest Global Heat Transfer Fluids Market

Report Scope:-

Report Features	Description
Market Value (2022)	USD 4.9 Bn
Forecast Revenue (2032)	USD 8.3 Bn
CAGR (2023-2032)	5.6%
Base Year for Estimation	2022
Historic Period	2016-2022
Forecast Period	2023-2032
Report Coverage	Revenue Forecast, Market Dynamics, COVID-19 Impact, Competitive Landscape, Recent Developments
Segments Covered	By Type (Silicone Fluids, Aromatic Fluids, Mineral Oils, Glycol Based Fluids, Other Types), By Application (Oil & Gas, Chemical, Concentrated Solar Power, Food & Beverages, Plastics, Pharmaceutical, HVAC, Other Applications)
Regional Analysis	North America – The US, Canada, & Mexico; Western Europe – Germany, France, The UK, Spain, Italy, Portugal, Ireland, Austria, Switzerland, Benelux, Nordic, & Rest of Western Europe; Eastern Europe – Russia, Poland, The Czech Republic, Greece, & Rest of Eastern Europe; APAC – China, Japan, South Korea, India, Australia & New Zealand, Indonesia, Malaysia, Philippines, Singapore, Thailand, Vietnam, & Rest of APAC; Latin America – Brazil, Colombia, Chile, Argentina, Costa Rica, & Rest of Latin America; Middle East & Africa – Algeria, Egypt, Israel, Kuwait, Nigeria, Saudi Arabia, South Africa, Turkey, United Arab Emirates, & Rest of MEA
Competitive Landscape	BASF SE, Dynalene, Inc., Indian Oil Corporation Ltd., KOST USA, Inc., Delta Western, Inc., Hindustan Petroleum Corporation Ltd., Royal Dutch Shell Plc, Dow Chemicals, Other Key Players
Customization Scope	Customization for segments, region/country-level will be provided. Moreover, additional customization can be done based on the requirements.
Purchase Options	We have three licenses to opt for: Single User License, Multi-User License (Up to 5 Users), Corporate Use License (Unlimited User and Printable PDF)

CHAPTER 5: CONCLUSION AND FINDINGS

CONCLUSION

Industrial thermal fluid heaters deliver a variety of benefits that make them an ideal choice for oil and gas heating applications:-

- **Easy Operation and Low Maintenance:** Thermal fluid heaters are low maintenance and easy to operate. Thermal oils can lubricate the thermal fluid heater so that the heater does not require monitoring or chemical treatment to prevent corrosion.
- **Reduced Energy Consumption:** Thermal fluid heaters offer up to 20% less energy consumption than steam heaters, avoiding heat loss from feedwater preheating, blowdown, and steam traps.
- **Decreased Emissions:** These heaters also result in reduced total exhaust emissions due to higher thermal efficiency.
- **Higher Operating Temperatures:** Because thermal oil's boiling point is higher than that of water, thermal fluid heaters can operate at a higher temperature range (-40 to 750 °F or -40 to 400 °C) than steam heaters can. Thermal fluid heaters can also heat process fluids at a range of different operating temperatures using secondary control loops.
- **Better Safety:** Since thermal fluid heaters operate at lower pressures than steam boilers, thermal fluid heaters don't provide a risk of pressure related explosion to facility personnel.

Cost-Effectiveness of Thermal Fluid Heaters

Thermal fluid heaters are a cost-effective solution for the oil and gas industry. Compared to steam systems, thermal fluid systems offer more long-term cost savings in the form of reduced maintenance and lower overall operating expenses. Plus, thermal fluid heaters certified under ASME Section VIII typically don't require a licensed boiler on site.

Industrial thermal fluid heaters offer up to 20% in fuel savings compared to steam heating systems by eliminating the potential for steam traps, blowdown, and feedwater preheating, all of which may cause heat loss and force the system to work harder to maintain the desired temperature.

CHAPTER 8: REFERENCES AND BIBLIOGRAPHY

Internet Sources

End of Project Report